

DELAWARE ELEVATOR

Manufacturing, Inc.

Delaware Elevator Manufacturing, Inc.

Factory Location

27685 Rockawalkin Ridge Rd.
Salisbury, Maryland 21801
Ph: (410) 749-3489
Fax: (410) 749-3934

Delaware Elevator National Sales

360 Pierce Ave.
Suite 207
N. Mankato, MN 56003
Ph: (443) 497-0155
Fax: (507) 389-4569

Electrical Data for Hydraulic 3 Phase Motors (80 Starts Per Hour) in a Submersible Power Unit

| HP | VOLT | Full Load Amps | Locked Rotor Amps (X-Line) |
|----|---------|----------------|----------------------------|
| 15 | 208 | 51 | 242 |
| 15 | 230/460 | 45/22.5 | 204/102 |
| 20 | 208 | 66 | 311 |
| 20 | 230/460 | 56/28 | 270/135 |
| 25 | 208 | 78 | 391 |
| 25 | 230/460 | 68/34 | 340/170 |
| 30 | 208 | 90 | 471 |
| 30 | 230/460 | 78/39 | 410/205 |
| 40 | 208 | 120 | 671 |
| 40 | 230/460 | 104/52 | 584/292 |
| 50 | 208 | 142 | 920 |
| 50 | 230/460 | 123/62 | 800/400 |

Locked Rotor AMPS are given for X-Line starting. Starting AMPS are 1/3 Locked Rotor AMPS when starting Wye-Delta.

To calculate approximate HP required:

$$\frac{\text{Gross Load} \times \text{Speed (FPM)}}{33.000} \times 125\%$$

----- or -----

$$\frac{\text{Full Load PSI} \times \text{GPM}}{1371}$$

Submersible Power Units

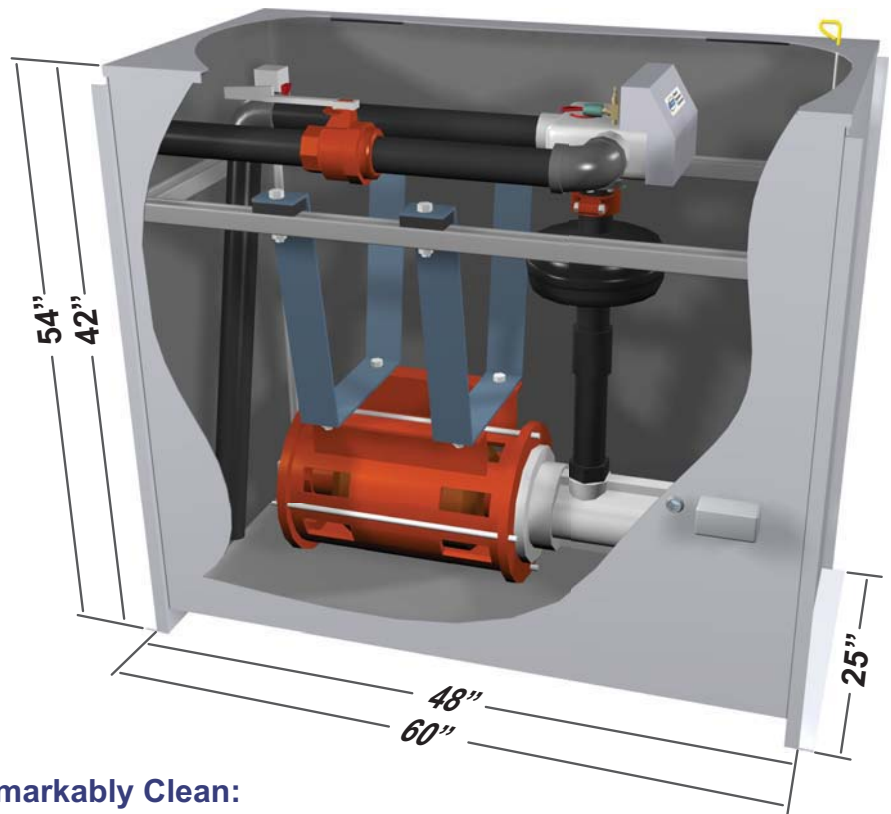

Remarkably Clean:

- With Delaware Elevator Manufacturing's unique design, your machine room will remain free of oil spills as all components are inside the tank (including the optional shut-off valve).

Attractive Compact Design:

- The DEM submersible power unit has been designed to fit through small (26") machine room doorways.

Standard Equipment:

- Motors: 15-50HP 3PH
- IMO Pumps: 24-253 GPM
- EECO Valve Standard (Mounted Inside the Tank)
- 12 ga. Enamel Tank
- Isolated Anchoring Feet
- Noise Reducing Muffler
- Oil Level Dip Stick
- Isolated Pump/Motor Suspension for Easy Removal & Quiet Operation
- Protective Packaging on a Pallet

Options:

- Maxton Valve
- Constant Down Speed Valves
- Custom Tank Sizes
- Low Pressure Switch
- Low Oil Switch
- Tank Heater
- Oil Cooler
- Oil Level Sight Gauge
- Shut Off(Ball) Valve
- Oil Return Pump
- **DEM can meet your custom needs, call if requested options are not listed above.**

▶ Visit www.DelawareElevator.com for a **3D Virtual Tour** of this Power Unit as well as our RFQ form.

“Quality Elevator Equipment For Every Rising Need”

